

Phys171 - Thu 3/1

Today: Chapter 8

Homework due Fri

Midterm returned next week Mon or Thu

Fri/Mon/Tue Chapter 9

Thu Quiz on Ch 9

Newton's Third Law

The force F_{12} exerted by object 1 on object 2 is equal in magnitude and opposite in direction to the force F_{21} exerted by object 2 on object 1

$$\mathbf{F}_{12} = -\mathbf{F}_{21}$$

- Action = reaction
- It doesn't matter which is considered the action and which the reaction
- Deals with Interactions between TWO objects (unlike Newton's 2nd law which looks at the forces exerted on one object)

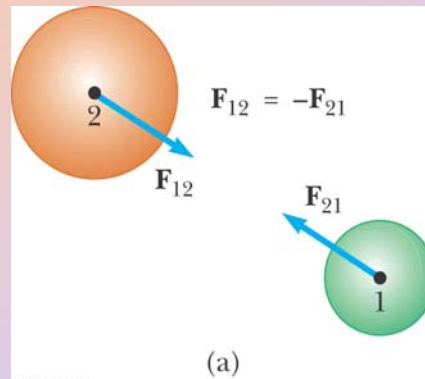

Example of Newton's 3rd law

Monitor on table

- Table pushes monitor upward (normal force)
- Monitor pushes table downward

(action/reaction pair)

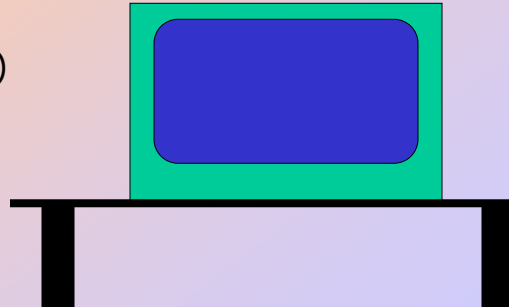

In Newton's 2nd law use ONLY the force acting ON the object of interest (example: normal force to compute forces on monitor)

- Apply equilibrium equation (Newton 2nd law) to the traffic light and find T_3

- Note: Object pulling a rope with a force: the magnitude of that force, T , is the tension in the rope

Use Newton's 3rd law: Traffic Light pulls on knot with same Magnitude and opposite direction of force as knot pulls on light

- Apply equilibrium equations to the knot and find T_1 and T_2

Tension in strings

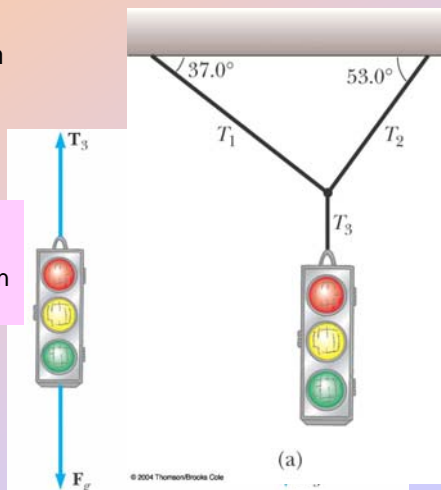

In the figures shown, all the green boxes have the same mass and all the pulleys are identical. In which case is the tension in the string **greater**?

1. Case A
2. Case B
3. They are the same
4. You can't tell.

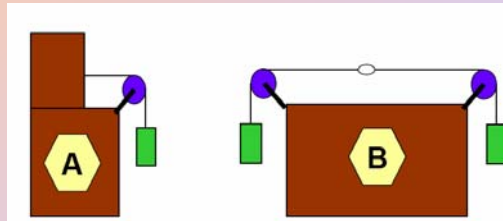

A piano mover raises a 100-kg piano at a constant rate using the frictionless pulley system shown here. With how much force is he pulling on the rope? Ignore friction and assume $g = 10 \text{ m/s}^2$.

1. 2,000 N
2. 1,500 N
3. 1,000 N
4. 750 N
5. 500 N
6. 200 N
7. 50 N
8. impossible to determine

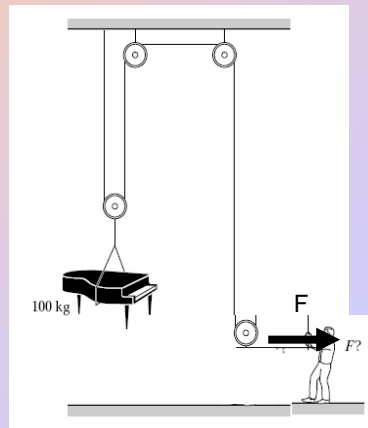

Suppose you are on a cart, initially at rest on a track with very little friction. You throw balls at a partition that is rigidly mounted on the cart. If the balls bounce straight back as shown in the figure, is the cart put in motion? ©Mazur

1. Yes, it moves to the right.
2. Yes, it moves to the left.
3. No, it remains in place.

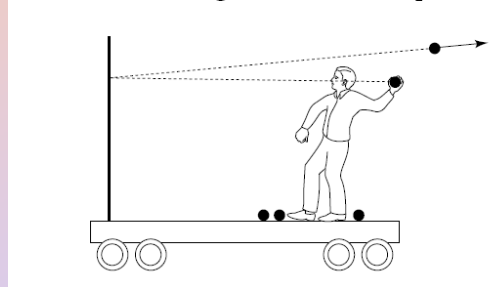

Conservation laws

